

SIMPSON

Strong-Tie

®

Attach **Trusses**
and **Rafters**
Faster

Strong-Drive[®]
STRUCTURAL FASTENERS

SDWC TRUSS Screw

Truss-to-Plate Connections

For Truss-to-Plate Connections

The Strong-Drive® SDWC **TRUSS** screw provides a truss- and rafter-to-top-plate connection. The fully threaded shank engages the entire length of the fastener providing a secure connection. The SDWC uplift values listed were analysed and calculated based on the characteristic values determined following AS1649-2001 (*Timber-Methods of Test for Mechanical Fasteners and Connectors – Basic Working Loads and Characteristic Strength*). The SDWC has also been tested in accordance with ICC-ES AC233 (screw) and AC13 (wall assembly and roof-to-wall assembly) for uplift and lateral loads between wall plates and vertical wall framing and between the top plate and the roof rafters or trusses.

Features:

Orange colour for easy inspection of 152 mm screws

6-Lobe Drive reduces cam out, enabling easier driving

Fully-threaded shank engages the entire length of the fastener, providing a secure connection between the roof and wall framing members

Cap-style head countersinks fully into the double top plate to avoid interference with drywall or finish trades

E-Coat™ Black electrocoating for 114 mm screws

Type-17 point for faster starts and easier driving

Installation guide (included) to help ensure proper installation angle

- Wide tolerance on installation angle makes it easy to install the SDWC correctly
- Matched-tolerance driver bit (included) engages fastener head securely to allow one-handed driving (replacement bit part no. BIT30T-R1)
- Can be installed from inside the structure, eliminating exterior work on the upper stories and enhancing job safety
- Fastening can be performed before or after exterior sheathing is applied for added flexibility

Product and Packaging Information

Fastener Model	Length (mm)	Finish	Bit Included	Guide Included	Fasteners Per Pack	Packs Per Carton	Model No.
SDWC15600	152	Clear Zinc Coating (with Orange Topcoat)	BIT30T	SDWC-GUIDE	50	6	SDWC15600-KT
SDWC15450	114	E-Coat Black	BIT30T	SDWC-GUIDE275	50	6	SDWC15450-KT

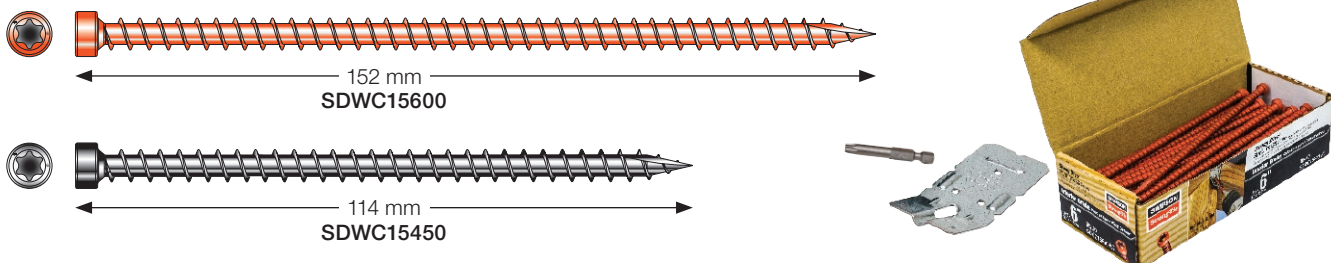

General Load Information

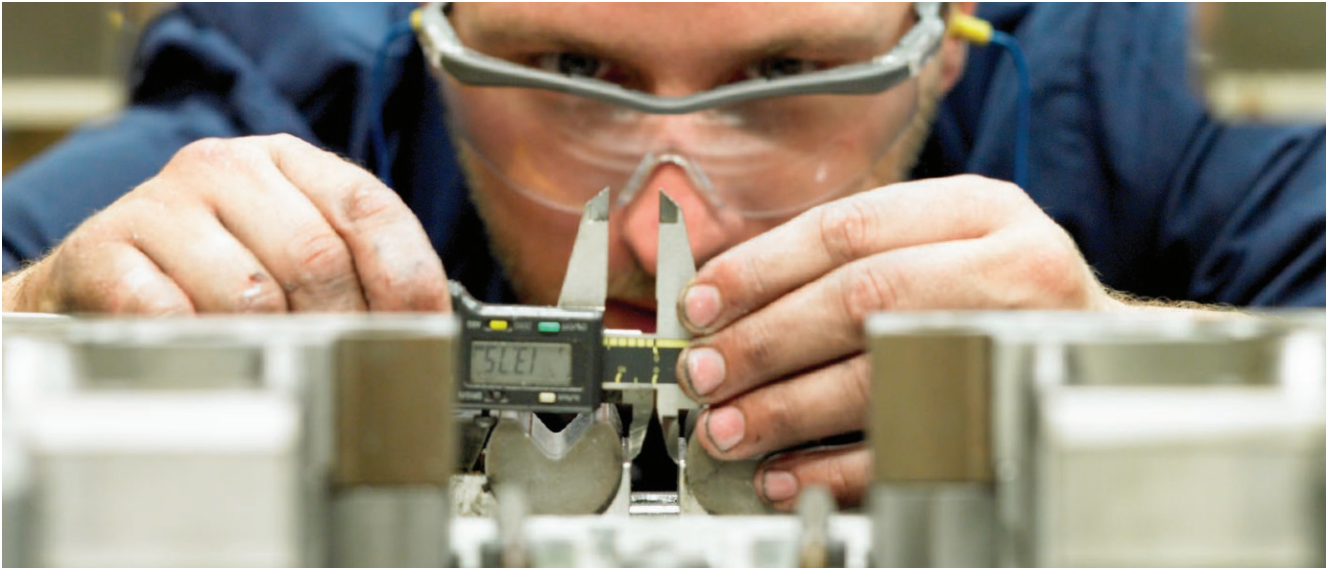

WHEN PERFORMANCE IS CRITICAL

Best-in-class, load-tested fasteners: Strong-Drive® structural fasteners are engineered and extensively tested to efficiently meet your most demanding applications. Stronger can also be faster. The Strong-Drive family is designed to install easier than other fastening methods, which saves time and money.

Strong-Drive SDWC TRUSS Screw Specifications

Fastener Model	Fastener Length (mm)	Thread Length (mm)	Diameter (mm)			Fastener Strength		
			Head	Major	Minor	Bending Yield Strength (MPa)	Tension (kN)	Shear (kN)
SDWC15450	114	108	8.31	5.97	3.86	1345	15.5	10.9
SDWC15600	152	146						

1. For the purposes of measuring overall length, fasteners shall be measured from the top of the head to the end of the point. Length of thread includes the point.
2. Bending yield strength is the 5%-offset value based on the minor diameter as determined following ASTM F1575.
3. Tension and shear properties are average ultimate values. Shear strength is shear through the threads.

SDWC TRUSS Screws Characteristic Single-Shear Lateral Design Loads

Fastener Model	Fastener Length (mm)	Thread Length (mm)	Side Member		Main Member		Lateral Characteristic Design Value, Q _{kl} (N)			
			Thickness (mm)	Grain	Min. Thickness (mm)	Grain	Q _{kl para}		Q _{kl perp}	
							JD4	JD5	JD4	JD5
SDWC15450	114	108	38	Face	38	End	—	—	2220	2220
			2-38	Face	38	Edge	4200	3500	5300	5100
SDWC15600	152	146	38	Face	38	End	—	—	2950	2650
			2-38	Face	38	End	—	—	4650	4150

1. The Main Member is the part where the fastener tip is embedded; the Side Member is part adjacent to the head.
2. Minimum penetration into the main member shall be 25 mm.
3. The main and side members shall be sawn timber or structural composite timber with the design density or equivalent design density typical of JD4 and JD5 grades.
4. Characteristic design values shall be multiplied by applicable adjustment factors from AS 1720.1.
5. Screws shall be installed into the side grain of the timber side member with the screw axis at a 90-degree angle to the surface of the member.
6. Para: Parallel-to-grain loading in the side member and perpendicular-to-grain loading in the main member.
7. Perp: Perpendicular-to-grain loading in the side member and perpendicular-to-grain loading in the main member, except where the main member is loaded parallel-to-grain.

General Load Information

SDWC TRUSS Screws Characteristic Withdrawal and Pull-Through Loads

Fastener Model	Thread Length (mm)	Thread Length (mm)	Main Member		Withdrawal Characteristic Design Value, Q_{kw} (N/mm)		Pull-Through Characteristic Design Value, Q_{kg} (N/mm)	
			Min. Thickness (mm)	Grain	JD4	JD5	JD4	JD5
SDWC15450	114	108	38	Edge	133	84	—	—
SDWC15600	152	146	38	End	78	50	96	82
			38	Face	110	75	108	97
			2-38	Face	118	102	131	105

1. Withdrawal and pull-through characteristic values are in N/mm of thread penetration into the main member and side member, respectively.
2. Face and edge installations are at 90 degrees to the face or edge installation is along the grain.
3. Withdrawal and Pull-through loads shall be checked against tension strength in design.

SDWC TRUSS Screws Connection Geometry

Condition		Minimum Distance or Spacing (mm)	
		SDWC15450	SDWC15600
Edge Distance	Load in any direction	30	30
	Load Along Grain Toward End	60	60
End Distance	Load Along Grain Way From End	60	60
	Loading Across Grain	60	60
Spacing Between Fasteners in a Row	Loaded Along Grain	90	90
	Loaded Across Grain	60	60

1. Edge distances, end distances, and spacing of screws shall be sufficient to prevent splitting of the timber or as required in this table, or when applicable, as recommended by the structural composite timber manufacturer, whichever is more restrictive.
2. Edge and end distances based on AS 1720.1, Table 4.8.

SDWC TRUSS Screw Uplift Capacity

Uplift values listed below were analysed and calculated based on the characteristic values determined following AS1649-2001 (Timber-Methods of Test for Mechanical Fasteners and Connectors-Basic Working Loads and Characteristic Strength).

Top Plate (mm)	Uplift Capacity (kN)	
	JD4	JD5
SDWC15450		
35	3.3	2.9
45	4.2	3.4
2-35	—	—
SDWC15600		
35	3.3	2.9
45	4.2	3.8
2-35	6.1	3.9

1. Installation Angles:
 - Truss aligned with stud 10°-30° to vertical
 - Truss offset from stud 0°-30° to vertical
2. Capacity factor for Category 1 is 0.85

Number of SDWC TRUSS Screws to resist uplift loads per AS1684.2-2010, Table 9.5

Timber	Top plate (mm)	Wind and Roof Conditions					
		N1 Sheet	N1 Tile	N2 Sheet	N2 Tile	N3 Sheet	N3 Tile
SPAN: 10 m							
JD5	2-35	1	—	1	1	2	1
	1-45	1	—	1	1	2	2
JD4	2-35	1	—	1	1	1	1
	1-45	1	—	1	1	2	1
SPAN: 14 m							
JD5	2-35	1	—	1	1	2	2
	1-45	1	—	2	1	N/A ⁵	2
JD4	2-35	1	—	1	1	2	1
	1-45	1	—	2	1	N/A ⁵	2

1. Applicable to SDWC15600 Truss screws.
2. Rafter/truss spacing for sheet roofs assumed to be 0.9 m, spacing for tile roofs assumed to be 0.6 m.
3. Calculation of withdrawal followed AS1720.1, section 4.3.3.4, $\phi=0.85$, $k_{13}=1.0$; Q_{kw} from L-F-SDWCAUS15.
4. Calculation for pull-through using the same method as for withdrawal.
5. Load capacity exceeds that of two SDWC15600.

Roof-to-Wall Connections

Option 1 Installation Instructions

These instructions apply if the truss is either aligned with or offset from the stud below.

Note: SDWC screws install best with a minimum 18V (if cordless) drill using the matched-tolerance bit included in the SDWC15600KT.

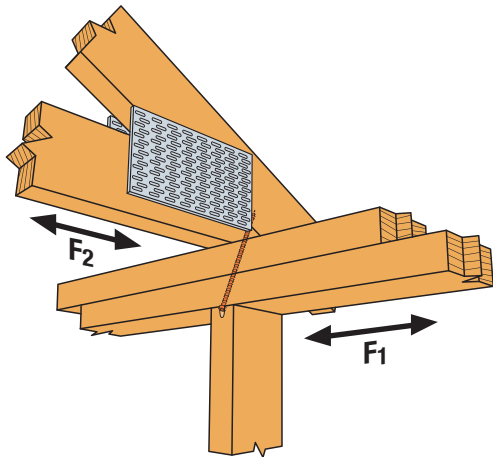

Typical SDWC installation – truss aligned with stud
(Offset truss similar)

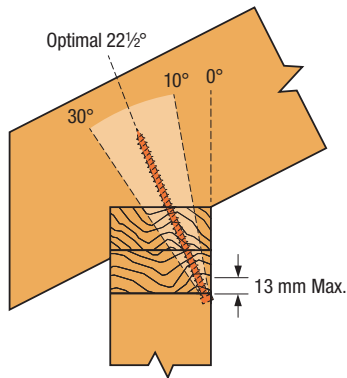

Installation angle limit

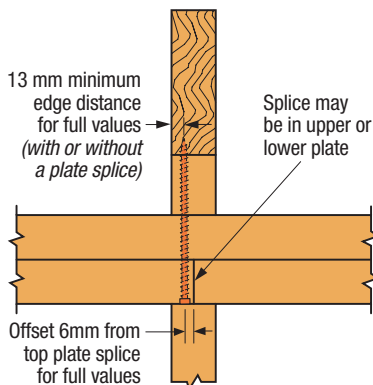

Min. edge distance for top plate splice



STEP 1 – Align the metal installation guide tool (included) with the truss, and drive the tip of the Strong-Drive SDWC to engage the threads.



STEP 2 – While continuing to drive the SDWC, “drop” the fastener head into the guide channel to ensure optimal installation angle of 22°. The installation angle range is 10°-30° (see illustration). Once the installation angle is established, the metal installation guide tool may be removed.



STEP 3 – Drive the SDWC until the head of the fastener is fully countersunk into the double top plate. Verify that the entire shank of the fastener is installed into a timber member.

Note: Sloped-roof rafters may be sloped up to and including a 45° pitch and must be “birdsmouth” cut.

Roof-to-Wall Connections

Option 2 Installation Instructions

These instructions apply only if the truss is offset from the stud below.

Note: SDWC screws install best with a minimum 18V (if cordless) drill using the matched-tolerance bit included in the SDWC15600KT.

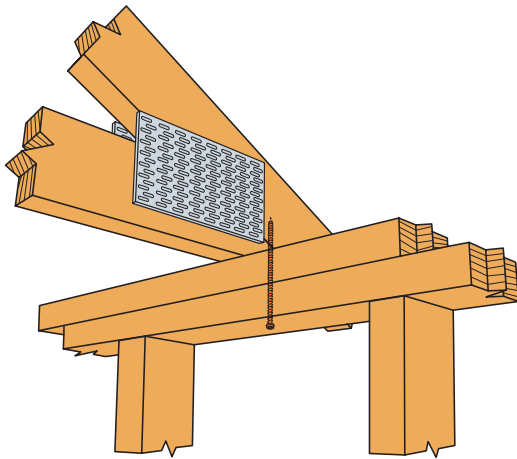

Optional SDWC installation – truss offset from stud

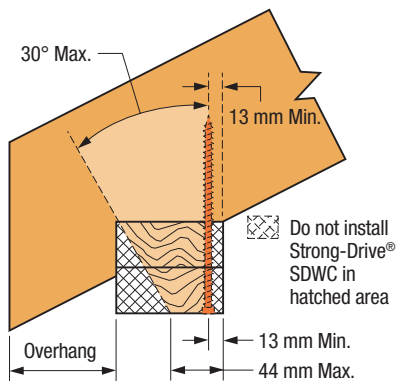

Allowable installation range
(Truss offset from stud only)

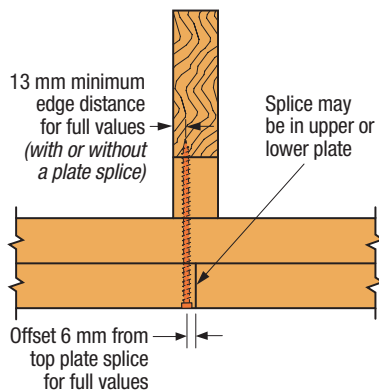

Min. edge distance for top plate splice



STEP 1 – Position point of the SDWC no less than 13 mm from edge of the double top plate. While perpendicular to the top plate is preferred, an installed angle up to and including 30° away from the installer is acceptable.



STEP 2 – Drive the SDWC until the head of the fastener is fully countersunk into the double top plate. Verify that the entire shank of the fastener is installed into a timber member.

Roof-to-Wall Connections

Option 3 Installation Instructions

These instructions apply where SDWC15600 two-screw installation configurations are required to resist uplift loads per AS1684.2-2010, Table 9.5.

Note: SDWC screws install best with a minimum 18V (if cordless) drill using the matched-tolerance bit included in the SDWC15600KT.

CONFIGURATION A (Truss Aligned with Stud)

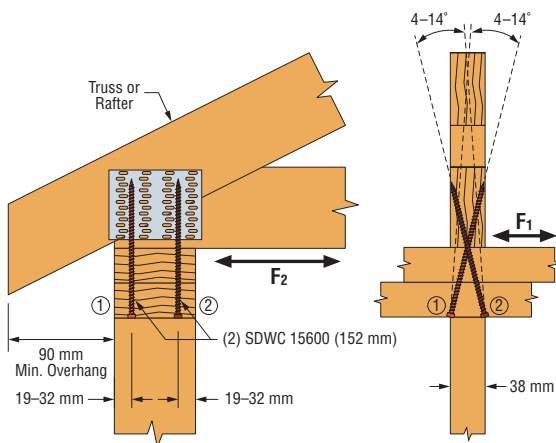

Install through Top Plate into Truss/Rafter

Both screws installed at a 4°–14° angle, offset 19–32 mm from opposite edges of the top plate.

CONFIGURATION B (Truss Offset from Stud)

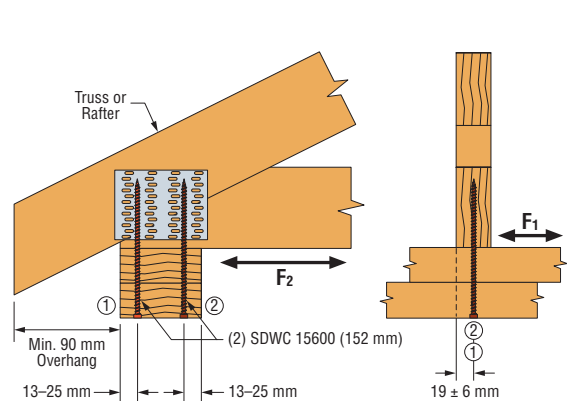

Install through Top Plate into Truss/Rafter

Both screws installed vertically ±5° into the center of the truss/rafter from the underside of the top plate, 13–25 mm from opposite edges of the top plate.

CONFIGURATION C

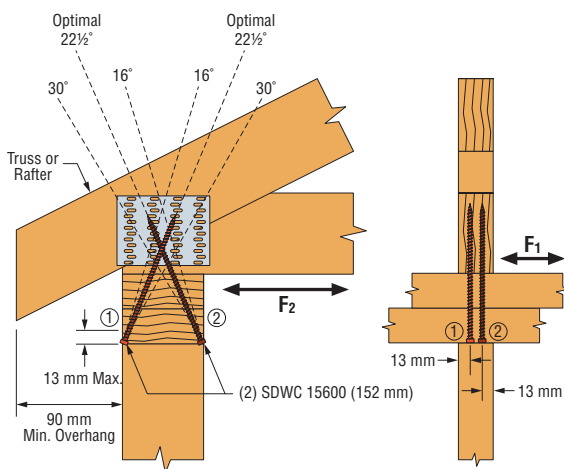

Install through Top Plate into Truss/Rafter

Both screws installed at a 16°–30° angle, offset 13 mm from the opposite edges of truss/rafter. Use metal installation guide included in screw kits for optimal 22.5° installation.

CONFIGURATION D

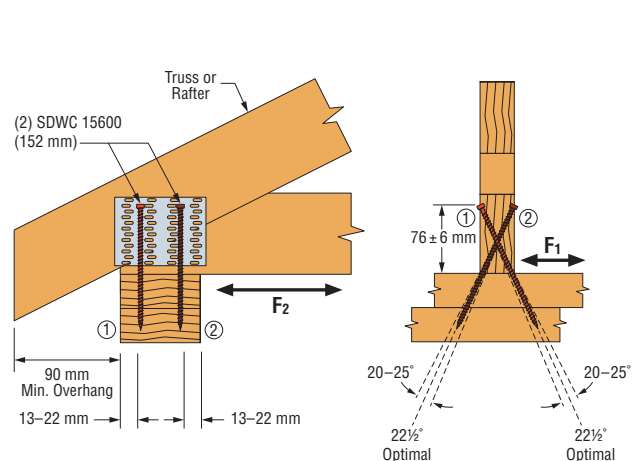

Install through Truss/Rafter into Top Plate

Both screws installed at a 20°–25° angle with a 13–22 mm offset from the opposite edges of top plate and 76±6 mm above top plate. Use metal installation guide included in screw kits for optimal 22.5° installation. To pre-drill through truss plates, use a 1/8" (3.2 mm) drill bit.

Roof-to-Wall Connections

Top Plate-to-Rafter with Non-Birdsmouth Rafter Connection

The SDWC15600 provides an alternate solution for Top Plate-to-Rafter where the rafter has no birdsmouth (as per AS1684.2 or AS1684.3 Table 9.4) and is adjacent to a ceiling joist that is fastened to the top-plate.

The SDWC15600 is driven vertically into the rafter (rafter slope of not more than 25°) and must penetrate the rafter by at least 40 mm to achieve specified wind uplift load values. The SDWC15600 screw can be installed vertically through the wedge (as per AS1684.2-2010, section 7.3.13.3) into the rafter for a complete connection, however, the absence of the wedge could affect the ultimate load capacity.

Strong-Drive SDWC TRUSS Screw Uplift Capacity for Top Plate-to-Rafter with Non-Birdsmouth Rafter Connection

Top Plate (mm)	Uplift Capacity (kN)
2-35	5.4
2-45	3.6

1. Rafter slope no more than 25°
2. Lateral loads and uplift are based on capacity factor 0.85
3. JD4 joint group connection design
4. SDWC15600 requires at least 40 mm penetration into the rafter

Option 4 Installation Instructions

These instructions apply only if the truss is offset from the stud below.

Note: SDWC screws install best with a minimum 18V (if cordless) drill using the matched-tolerance bit included in the SDWC15600KT.

FIGURE 1 – Non-birdsmouth rafter with SDWC15600 installed with double top plates and rafter angle of 25°. Ceiling joist not shown for clarity. Connection is illustrated with 2-45 mm top plates.

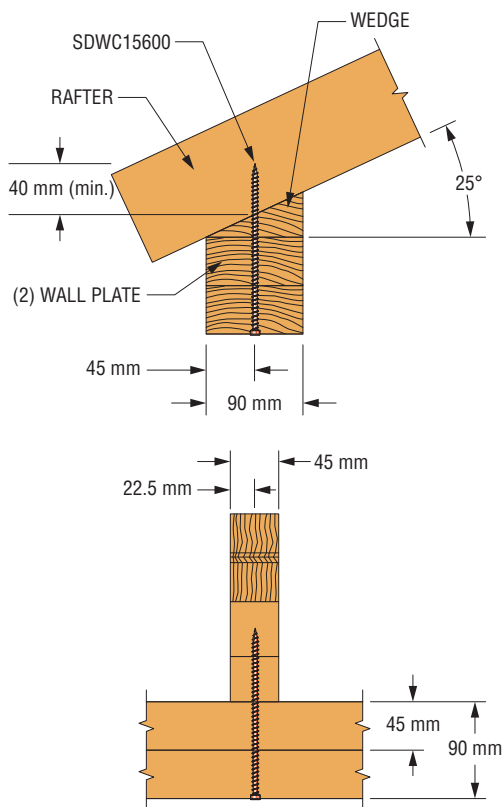

STEP 1 – Position point of the SDWC no less than 13 mm from edge of the double top plate. While perpendicular to the top plate is preferred, an installed angle up to and including 30° away from the installer is acceptable.

Please note: The SDWC15600 must penetrate the rafter by at least 40 mm to achieve specified uplift loads.



STEP 2 – Drive the SDWC until the head of the fastener is fully countersunk into the double top plate. Verify that the entire shank of the fastener is installed into a timber member.